

3/3 High Frequency Rack UPS

(10-40kVA)

User Manual

All rights reserved.

The information in this document is subject to change without notice.

Publish statement

Thank you for purchasing this series UPS.

This series UPS is an intelligent, three phase in three phase out, high frequency online UPS designed by our R&D team who is with years of designing experiences on UPS.

With excellent electrical performance, perfect intelligent monitoring and network functions, smart appearance, complying with EMC and safety standards, This UPS has become standard product which meets the world's advanced level.

Read this manual carefully before installation

This manual offers technical support for equipment operator

Contents

1. Safety	2
1.1 Safety notes	2
1.2 Symbols used in this guide	2
2. Main feature	3
2.1 Summarization	3
2.2 Functions and Features	3
3. Installation	4
3.1 Unpack checking	4
3.2 UPS Outlook	4
3.3 LCD display	4
3.4 Installation notes	5
3.5 External Protective Devices	5
3.6 Power Cables	6
3.7 Power cable connect	6
3.8 Battery connection	8
3.9 UPS Multi—Module Installation	9
3.10 LBS installation	10
3.11 Computer access	11
4. Operation	14
4.1 Operation Modes	14
4.2 Turn on/off UPS	16
4.3 The LCD Display	20
4.4 Options	20
Appendix 1 Specifications	22
Appendix 2 Problems and Solution	23
Appendix 3 USB communication port definition	24
Appendix 4 RS232 communication port definition	25
Appendix 5 RS485 communication port definition	26
Appendix 6 Optional port definition	27
Appendix 7 REPO instruction	28

1. Safety

Important safety instructions – Save these instructions

There exists dangerous voltage and high temperature inside the UPS. During the installation, operation and maintenance, please abide the local safety instructions and relative laws, otherwise it will result in personnel injury or equipment damage. Safety instructions in this manual act as a supplementary for the local safety instructions. Our company will not assume the liability that caused by disobeying local safety instructions.

1.1 Safety notes

1. Even no connection with utility power, 220/230/240VAC voltage may still exist at UPS outlet!
2. For the sake of human being safety, please well earth the UPS before starting it .
3. Don't open or damage battery, for the liquid spilled from the battery is strongly poisonous and do harmful to body!
4. Please avoid short circuit between anode and cathode of battery, otherwise, it will cause spark or fire!
5. Don't disassemble the UPS cover, or there may be an electric shock!
6. Check if there exists high voltage before touching the battery
7. Working environment and storage way will affect the lifetime and reliability of the UPS. Avoid the UPS from working under following environment for long time
 - ◆ Area where the humidity and temperature is out of the specified range(temperature 0 to 40°C, relative humidity 5%-95%)
 - ◆ Direct sunlight or location nearby heat
 - ◆ Vibration Area with possibility to get the UPS crashed.
 - ◆ Area with erosive gas, flammable gas, excessive dust, etc
8. Keep ventilation in good conditions otherwise the components inside the UPS will be over-heated which may affect the life of the UPS.

1.2 Symbols used in this guide



WARNING!

Risk of electric shock



CAUTION!

Read this information to avoid equipment damage

2. Main Features

2.1 Summarization

This series UPS is a kind of three-in- three -out high frequency online UPS, it provides three specifications: The 10KVA, 15KVA, 20KVA, 30KVA and 40KVA. The products are modularized and adopt the N+X redundancy. It can flexibly increase the number of the UPS modules according to the load capacity which is convenient for flexible allocation and gradually investment.

The UPS can solve most of the power supply problems, such as blackout, over-voltage, under-voltage, voltage sudden drop, oscillating of decreasing extent, high voltage pulse, voltage fluctuation, surge, inrush current, harmonic distortion (THD), noise interference, frequency fluctuation, etc..

This UPS can be applied to different applications from computer device, automatic equipment, communication system to industry equipment.

2.2 Functions and Features

◆3Phase In/3Phase Out UPS

It is 3Phase In/3Phase Out high-density UPS system, of which input current is kept in balance. No unbalance problem might occur.

◆Digital Control

This series UPS is controlled by Digital Signal Processor(DSP); it increases reliability, performance, self-protection, self-diagnostics and so on.

◆Compact Design

This series UPS adopts compact design concept. The capacities are available for 10KVA, 15KVA, 20KVA, 30KVA and 40KVA.

◆Battery Configurable from 30 blocks to 50 blocks

The battery voltage of this series UPS can be configured at 30 blocks,32 blocks, 34 blocks, 36 blocks, 38 blocks, 40 blocks, 42 blocks, 44 blocks , 46 blocks, 48 blocks or 50 blocks according to your convenience.

◆Charging Current is configurable

Via setting tool, the user may set the capacity of the batteries as well as reasonable charging current as well as maximum charging current. Constant voltage mode, constant current mode or floating mode can be switched automatically and smoothly.

◆Intelligent Charging Method

The series UPS adopts advanced three-stage charging method—

1st stage: high current constant current charging
to guarantee to charge back to 90%;

2nd-stage: Constant Voltage

In order to vitalize battery and make sure batteries are fully charged

3rd stage: floating mode.

With this 3-stage charging method, it extends the life of the batteries and guarantees fast charging.

◆LCD Display

With LCD plus LED displays, the user may easily get UPS status and its operational parameters, such as input/output voltage, frequency & load%, battery % and ambient temperature, etc..

◆Intelligent Monitoring Function

Via optional SNMP Card, you may remotely control and monitor the UPS.

◆EPO Function

The series UPS may be completely shut off when the EPO is pressed. REPO function(Remote EPO) is also available in this series UPS.

3. Installation

3.1 Unpack checking

1. Don't lean the UPS when moving it out from the packaging
2. Check the appearance to see if the UPS is damaged or not during the transportation, do not switch on the UPS if any damage found. Please contact the dealer right away.
3. Check the accessories according to the packing list and contact the dealer in case of missing parts.

3.2 UPS Outlook

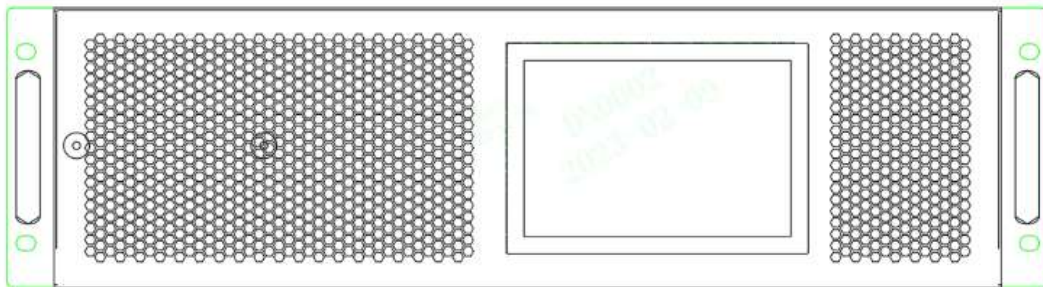

10-40K front view

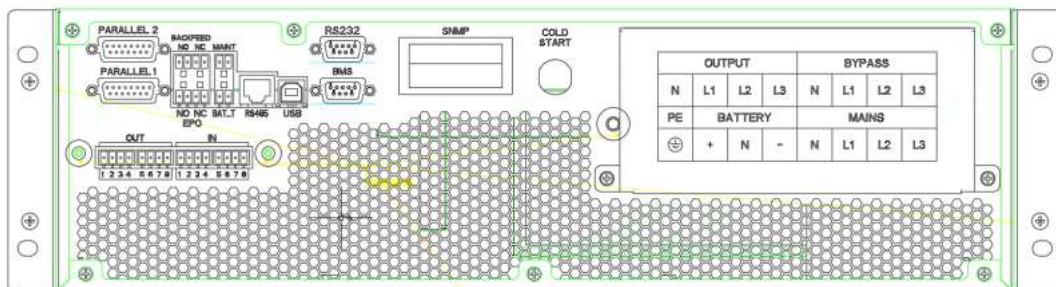

10-40K rear view

3.3 LCD display



LCD display

3.4 Installation notes

◆Please place the UPS in a clean, stable environment, avoid the vibration, dust, humidity, flammable gas and liquid, corrosive objects. To avoid from high room temperature, a system of room extractor fans is recommended to be installed. Optional air filters are available if the UPS operates in a dusty environment.

◆The environment temperature around the UPS should keep in a range of 0°C~40°C. If the environment temperature exceeds 40°C, the rated load capacity should be reduced by 12% per 5°C. The max temperature can't be higher than 50°C.

◆If the UPS is dismantled under low temperature, it might be in a condensing condition. The UPS can't be installed unless the internal and external of the equipment is fully dry. Otherwise, there will be in danger of electric shock.

◆Batteries should be mounted in an environment where the temperature is within the required specs. Temperature is a major factor in determining battery life and capacity. In a normal installation, the battery temperature is maintained between 15°C and 25°C. Keep batteries away from heat sources or main air ventilation area, etc.



WARNING!

Typical battery performance data are quoted for an operating temperature between 20°C and 25°C. Operating it above this range will reduce the battery life while operation below this range will reduce the battery capacity.

◆Should the equipment not be installed immediately it must be stored in a room so as to protect it against excessive humidity and or heat sources.



CAUTION!

An unused battery must be recharged every 6months. Temporarily connecting the UPS to a suitable AC supply and activating it for the time required for recharging the batteries are required.

◆The highest altitude that UPS may work normally with full load is 1500 meters. The load capacity should be reduced when this UPS is installed in place whose altitude is higher than 1500 meters, shown as the following table:

(Load coefficient equals max load in high altitude place divided by nominal power of the UPS)

Altitude (m)	1500	2000	2500	3000	3500	4000	4500	5000
Load coefficient	100%	95%	90%	85%	80%	75%	70%	65%

◆To get the UPS completely monitored by the software, you just simply connect RS232 cable to each end of the computer and the UPS respectively.

3.5 External Protective Devices

For safety reasons, it is necessary to install, external circuit breaker at the input A.C. supply and the battery. This chapter provides guidelines for qualified installers that must have the knowledge of local wiring practices for the equipment to be installed.

◆External Battery

The UPS and its associated batteries are protected against the effect of over-current through a DC compatible thermo-magnetic circuit-breaker (or a set of fuses) located close to the battery.

◆UPS Output

Any external distribution board used for load distribution shall be fitted with protective devices that may avoid the risk of UPS overloaded.

◆Over-current

Protection device shall be installed at the distribution panel of the incoming main

supply. It may identify the power cables current capacity as well as the overload capacity of the system .



CAUTION !

Select a thermo magnetic circuit-breaker with an IEC 60947-2 trip curve C (normal) for 125% of the current as listed below.

3.6 Power Cables

◆The cable design shall comply with the voltages and currents provided in this section, Kindly follow local wiring practices and take into consideration the environmental conditions (temperature and physical support media) .

WARNING !



UPON STARTING, PLEASE ENSURE THAT YOU ARE AWARE OF THE LOCATION AND OPERATION OF THE EXTERNAL ISOLATORS WHICH ARE CONNECTED TO THE UPS INPUT/BYPASS SUPPLY OF THE MAINS DISTRIBUTION PANEL.CHECK TO SEE IF THESE SUPPLIES ARE ELECTRICALLY ISOLATED, AND POST ANY NECESSARY WARNING SIGNS TO PREVENT ANY INADVERTENT OPERATION

Cable Dimension

UPS module	Cable Dimension			
	AC Input (mm ²)	AC Output (mm ²)	DC Input (mm ²)	Grounding (mm ²)
10/15KVA	4	4	6	4
20KVA	8	8	10	8
30KVA	12	12	16	12
40KVA	16	16	20	16



CAUTION!

Protective earth cable: Connect each cabinet to the main ground system. For Grounding connection, follow the shortest route possible .



WARNING!

FAILURE TO FOLLOW ADEQUATE EARTHING PROCEDURES MAY RESULT IN ELECTROMAGNETIC INTERFERENCE OR IN HAZARDS INVOLVING ELECTRIC SHOCK AND FIRE

3.7 Power cable connect

Once the equipment has been finally positioned and secured, connect the power cables as described in the following procedure.

Verify the UPS is totally isolated from its external power source and also all power isolators of the UPS are open. Check to see if they are electrically isolated, and post any necessary warning signs to prevent their inadvertent operation .

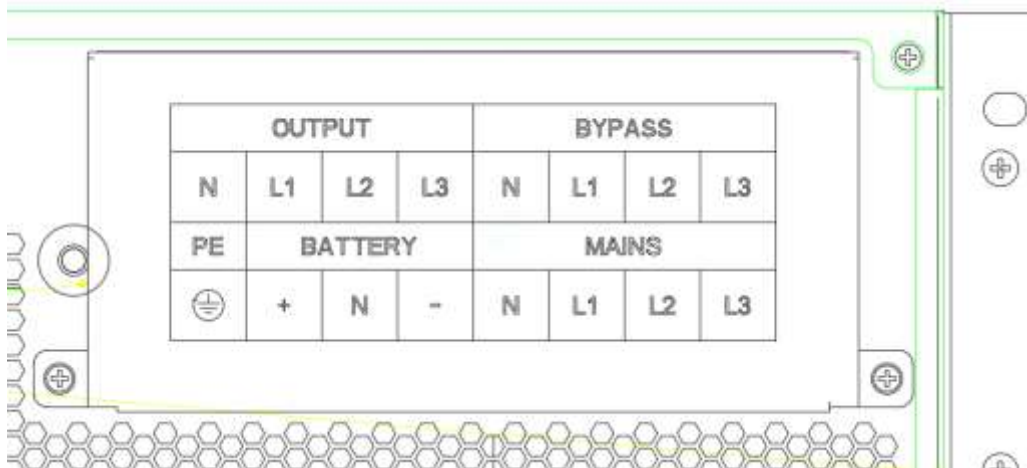

Terminal with cover

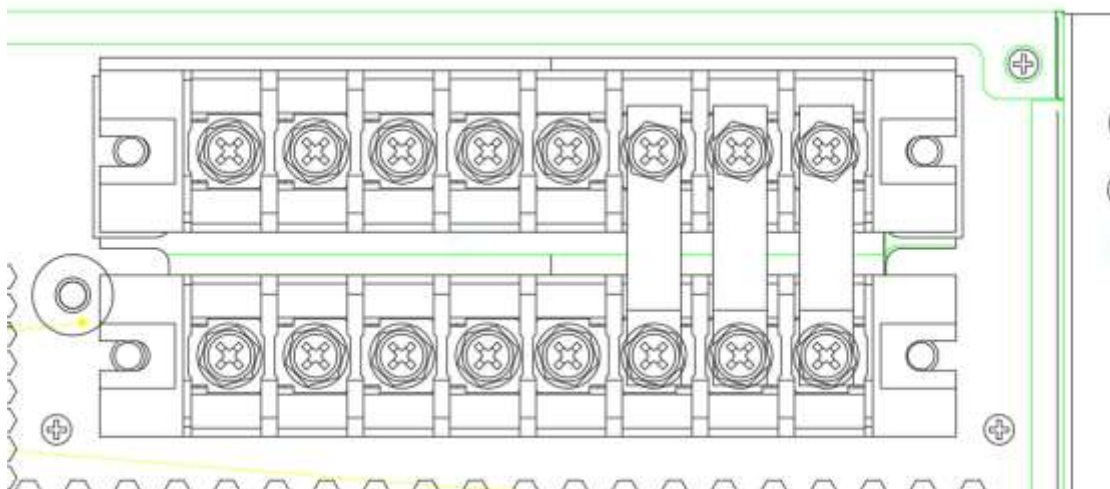

Terminal without cover

Choose appropriate power cable, and pay attention to the diameter of the connection terminal of the cable that should be greater than or equal to that of the connection poles;

Wiring

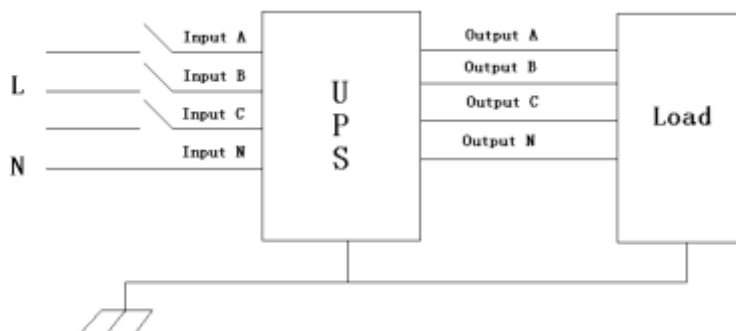

WARNING!

If the load equipment is not ready to accept power on the arrival of the commissioning engineer then ensure that the system output cables are safely isolated at their ends



CAUTION!

The earthing and neutral bonding arrangement must be in accordance with local and national codes of practice.

3.8 Battery connection

The UPS adopts positive and negative double battery framework, total 30(optional 32/34/36/38/40/42/44/46/48/50) in series. A neutral cable is retrieved from the joint between the cathode of the 15th (16th/17th/18 th/19th/20 th/21 th/22 th/23 th/24 th/25 th) and the anode of the 16th(17th/18th/19 th/20th/21 th/22 th/23th/24 th/25 th/26 th) of the batteries. Then the neutral cable, the battery Positive and the battery negative are connected with the UPS respectively. The battery sets between the Battery anode and the neutral are called positive batteries and that between neutral and cathode are called negative ones. The user can choose the capacity and the numbers of the batteries according to their desire.The connection is shown as following:

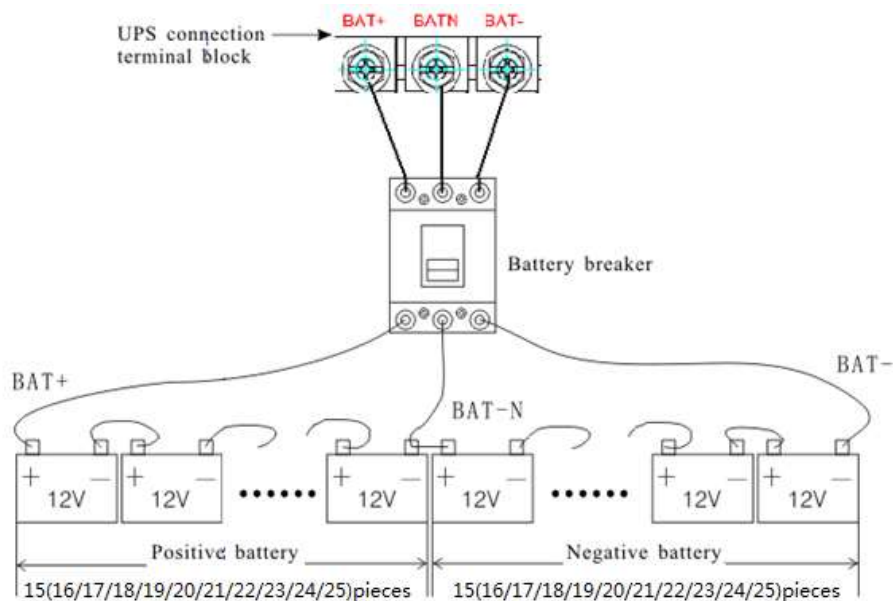

Note:

The BAT+ of the UPS connect poles is connected to the anode of the positive battery, the BAT-N is connected to the cathode of the positive battery and the anode of the negative battery, the BAT- is connected to the cathode of the negative battery.

Factory setting of the long-run unit is battery quantity---40pcs, battery capacity---12V100AH (charger current 15A). When connecting 30/32/34/36/38/42/44/46/48/50 batteries, please re-set desired battery quantity and its capacity after UPS starts at AC mode. Charger current could be adjusted automatically according to battery capacity selected. All related settings can be done through LCD panel or monitoring software



CAUTION!

Ensure correct polarity battery string series connection. i.e. inter-tier and inter block connections are from (+) to (-)terminals. Don't mix batteries with different capacity or different brands, or even mix up new and old batteries, either.



WARNING!

Ensure correct polarity of string end connections to the Battery Circuit

Breaker and from the Battery Circuit Breaker to the UPS terminals i.e. (+) to (+) / (-) to (-) but disconnect one or more battery cell links in each tier. Do not reconnect these links and do not close the battery circuit breaker unless authorized by the commissioning engineer.

3.9 UPS Multi—Module Installation

The basic installation procedure of a parallel system comprising of two or more UPS modules is the same as that of single module system. The following sections introduce the installation procedures specified to the parallel system.

3.9.1 Cabinet installation

Connect all the UPS needed to be put into parallel system as below picture.

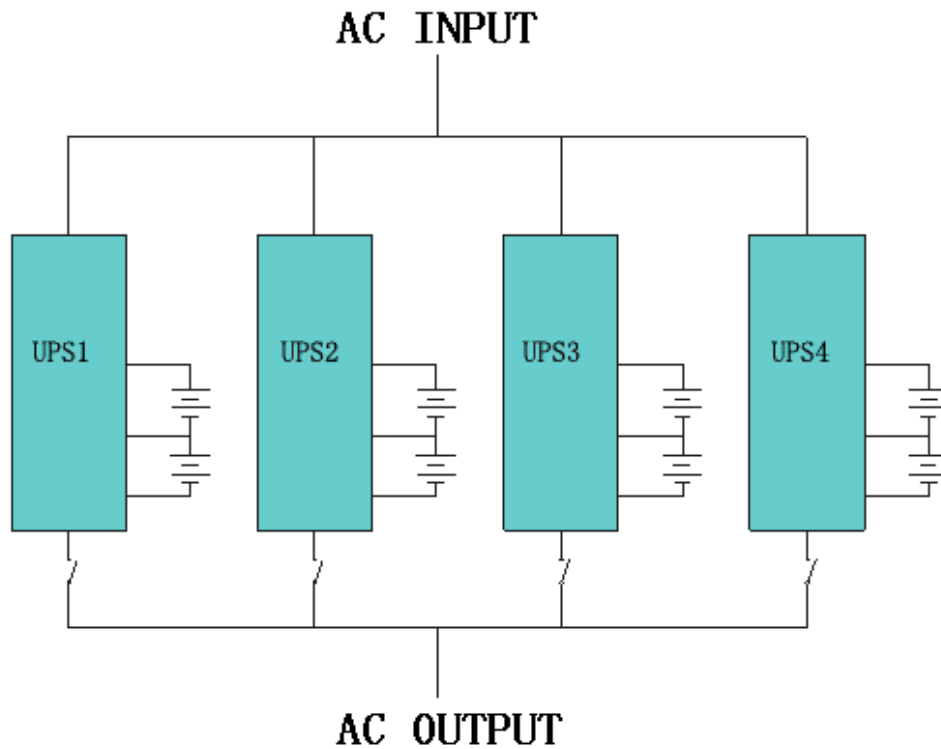

Make sure each UPS input breaker is in “off” position and there is no any output from each UPS connected. Battery groups can be connected separately or in parallel, which means the system itself provides both separate battery and common battery.



WARNING!

Make sure the N, A (L1), B (L2), C (L3) lines are correct, and grounding is well connected.

3.9.2 Parallel cable installation

Shielded and double insulated control cables available must be interconnected in a ring configuration between UPS modules as shown below. The parallel control board is mounted on each UPS module. The ring configuration ensures high reliability of the control.

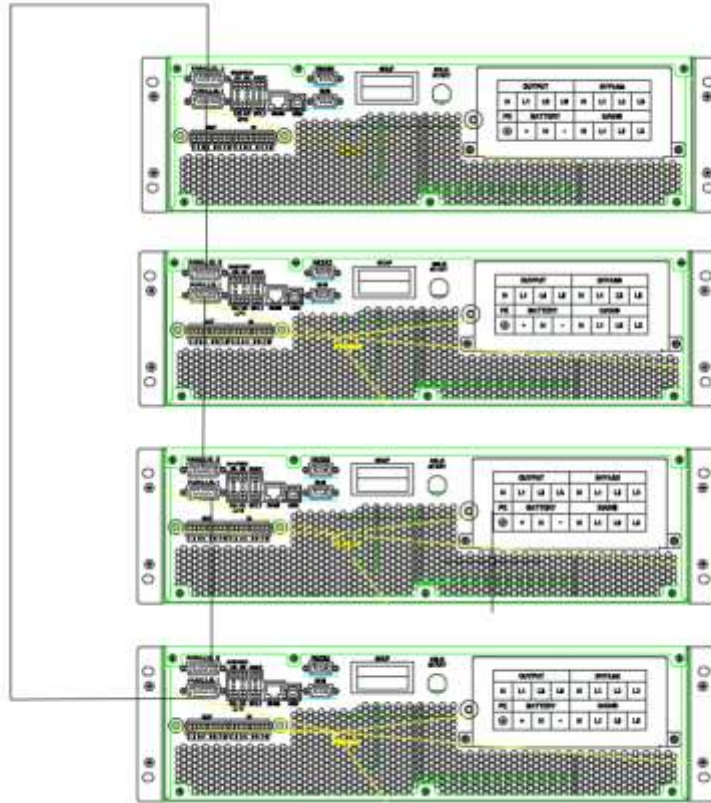

3.9.3 Requirement for the parallel system

A group of paralleled modules behave as one large UPS system but with the advantage of presenting higher reliability. In order to assure that all modules are equally utilized and comply with relevant wiring rules, please follow the requirements below:

- 1) All UPS modules must be of the same rating and be connected to the same bypass source.
- 2) The Bypass and the Main input sources must be referenced to the same neutral potential.
- 3) The outputs of all the UPS modules must be connected to a common output bus.
- 4) The length and specification of power cables including the bypass input cables and the UPS output cables should be the same. This facilitates load sharing when operating in bypass mode.

3.10 LBS installation

LBS system contains LCD set, communication cable and STS device.

3.10.1 LCD setting

Set every UPS of the systems to be LBS Master or LBS Slave. For instance if the UPS

belongs to LBS master system, its LBS setting must be set to Master.

3.10.2 LBS cable installation

The two ports of one mesh wire should be plug into RJ45 interface of any one UPS of both master and slave system.

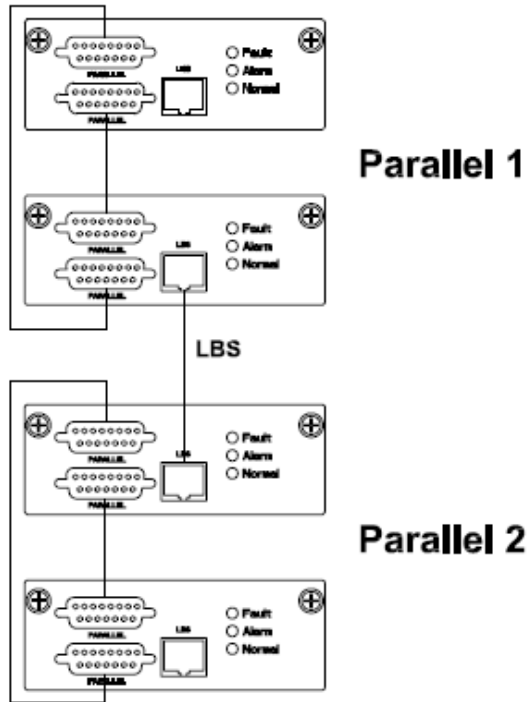

3.10.3 UPS installation

The whole systems is showed below.

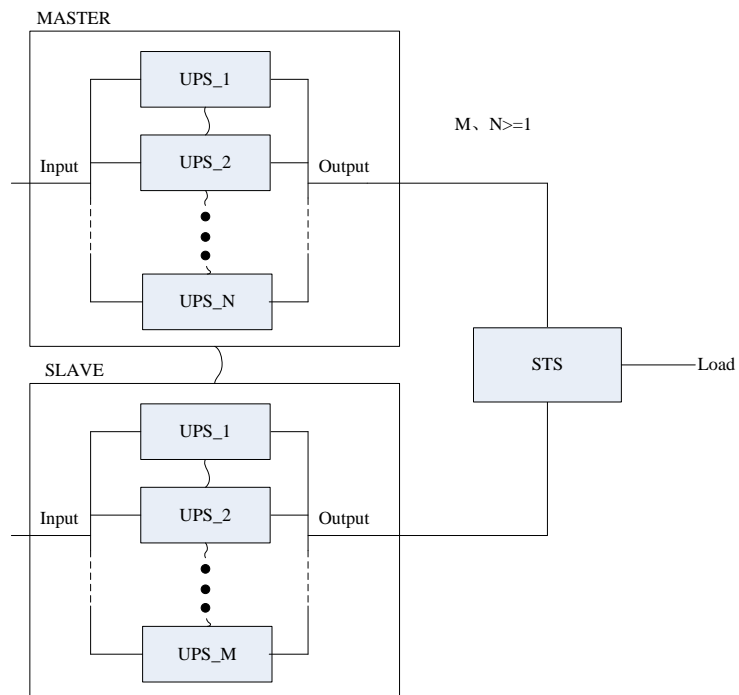

3.11 Computer access

◆ One end of a USB cable connect to the computer, the other end connect to the USB port on the UPS.

◆ Open the software Muser5000, click “system” button.



◆ A window of “Software Parameter Setting” comes out as below, COM choose according to the UPS , baud rate choose 9600, protocol choose “modbus”, then save this setting.

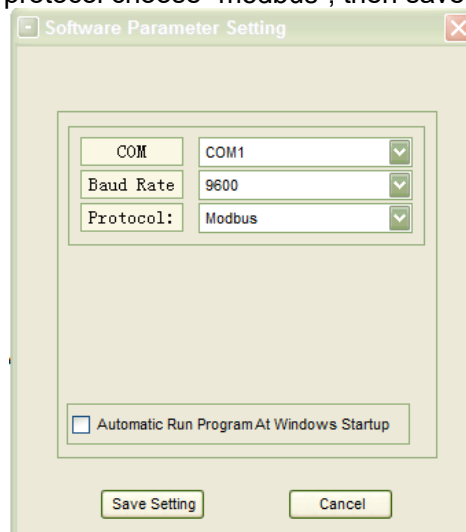

◆ On the main page of Muser5000, click the button of “Append”, then goes to a window of “Append equipment”.

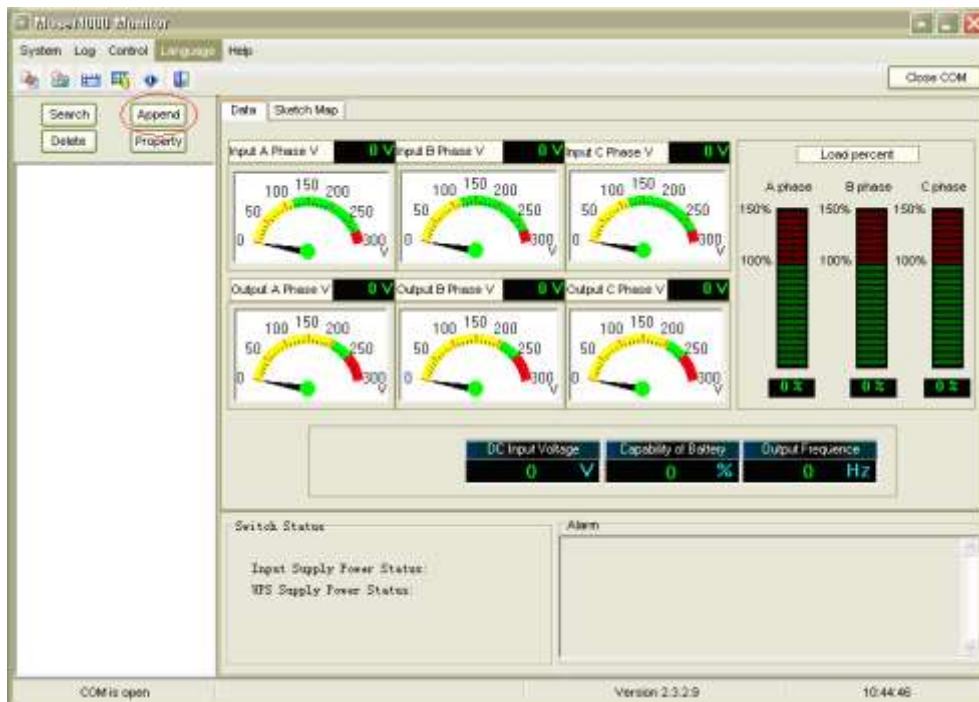

- ◆ Put the UPS name into “Equipment Name”, and UPS’ ID address into “Equipment address”.

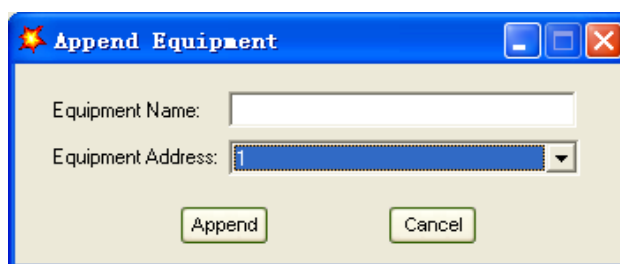

- ◆ Click the button “Append”, then the connection between UPS & computer is accomplished.



CAUTION!

When the UPS worked on inverter. If you want to use PC to set the output voltage and frequency. Must shut down the inverter first

4. Operation

4.1 Operation Modes

The UPS is a double-conversion on-line UPS that may operate in the following alternative modes:

◆ Normal mode

The rectifier/charger derives power from the AC Mains and supplies DC power to the inverter while floating and boosting charge the battery simultaneously. Then, the inverter converts the DC power to AC and supplies to the load.

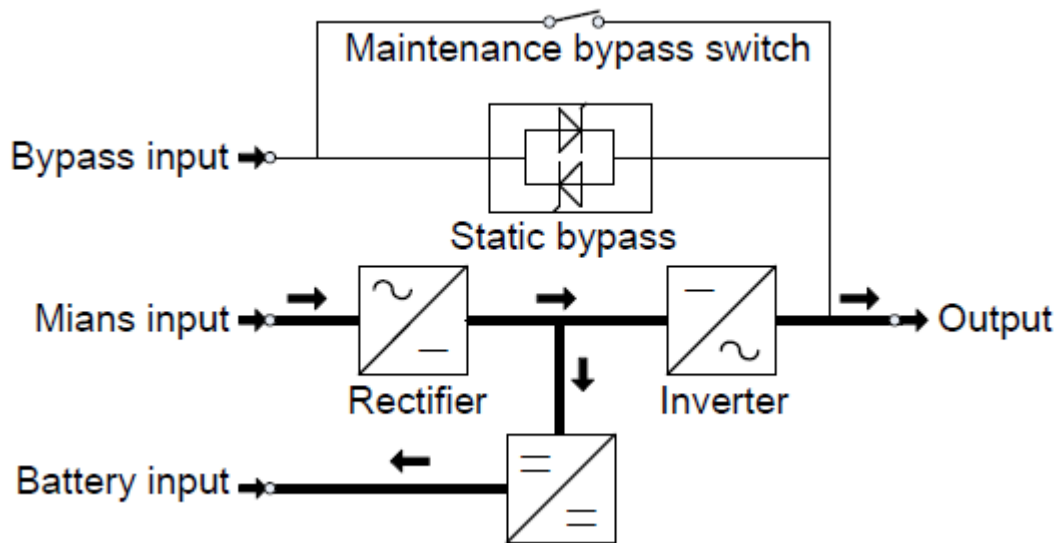

◆ Battery mode (Stored Energy Mode)

If the AC mains input power fails, the inverter, which obtains power from the battery, supplies the critical AC load. There is no power interruption to the critical load. The UPS will automatically return to Normal Mode when AC recovers.

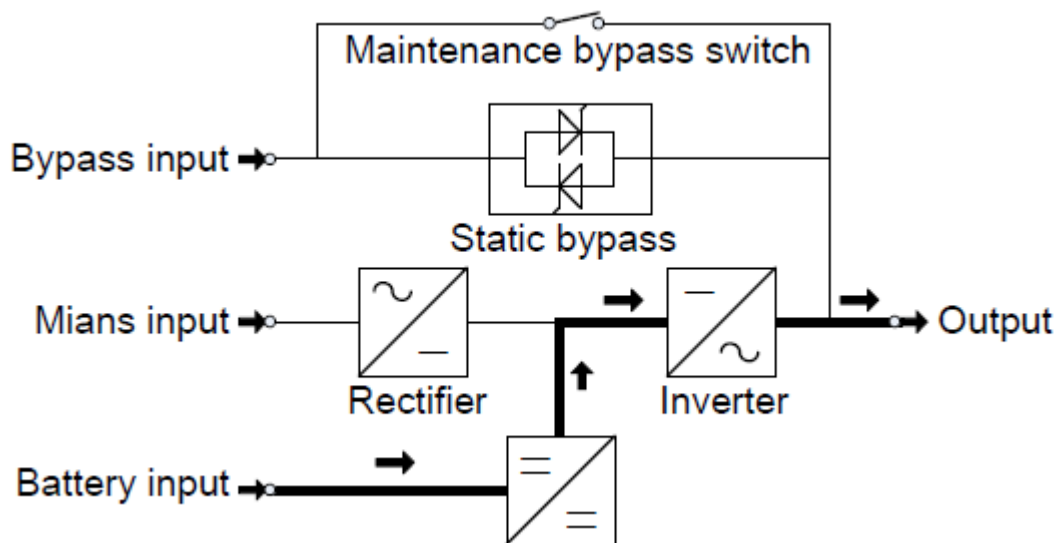

◆Bypass mode

If the inverter is out of order, or if overload occurs, the static transfer switch will be activated to transfer the load from the inverter supply to bypass supply without interruption to the critical load. In the event that the inverter output is not synchronized with the bypass AC source, the static switch will perform a transfer of the load from the inverter to the bypass with power interruption to the critical AC load. This is to avoid paralleling of unsynchronized AC sources. This interruption is programmable but typically set to be less than an electrical cycle e.g. less than 15ms (50Hz) or less than 13.33ms (60Hz).

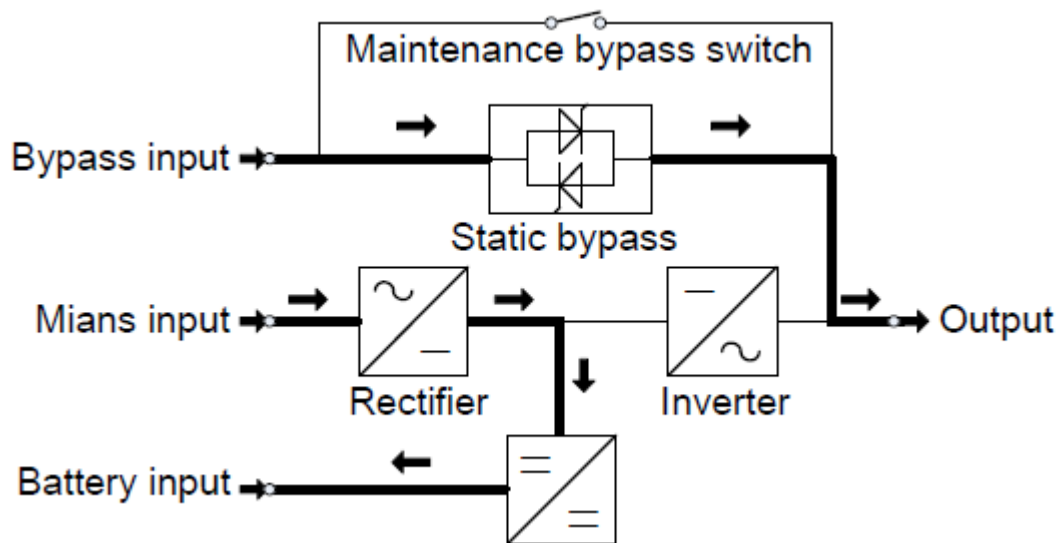

◆ECO Mode

When the UPS is at AC Mode and the requirement to the load is not critical, the UPS can be set at ECO mode in order to increase the efficiency of the power supplied. At ECO mode, the UPS works at Line-interactive mode, so the UPS will transfer to bypass supply. When the AC is out of set window, the UPS will transfer from bypass to Inverter and supplies power from the battery, and then the LCD shows all related information on the screen.

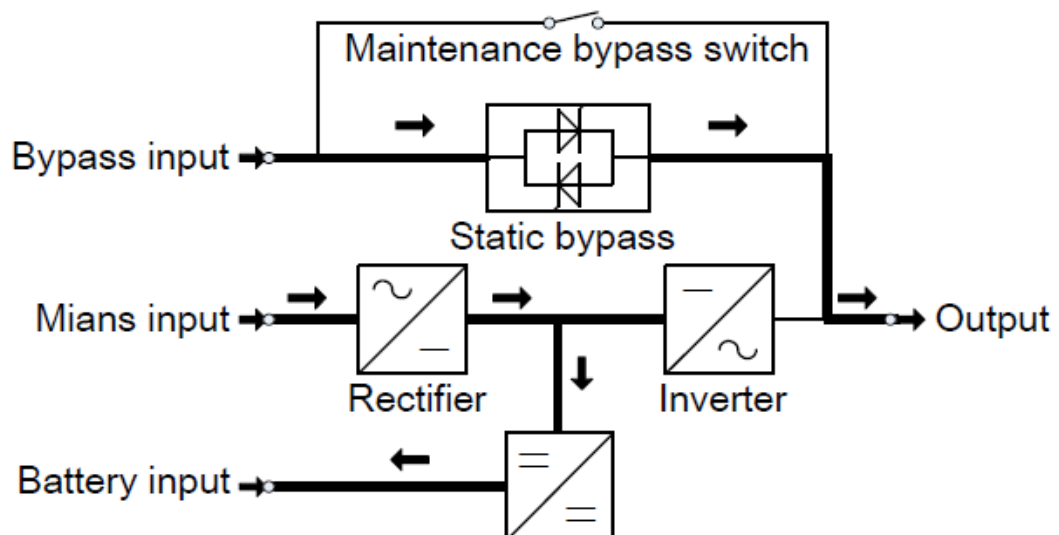

◆ Maintenance mode (Manual Bypass)

A manual bypass switch is available to ensure continuity of supply to the critical load when the UPS is out of order or in repair and this manual bypass switch bears for equivalent rated load.

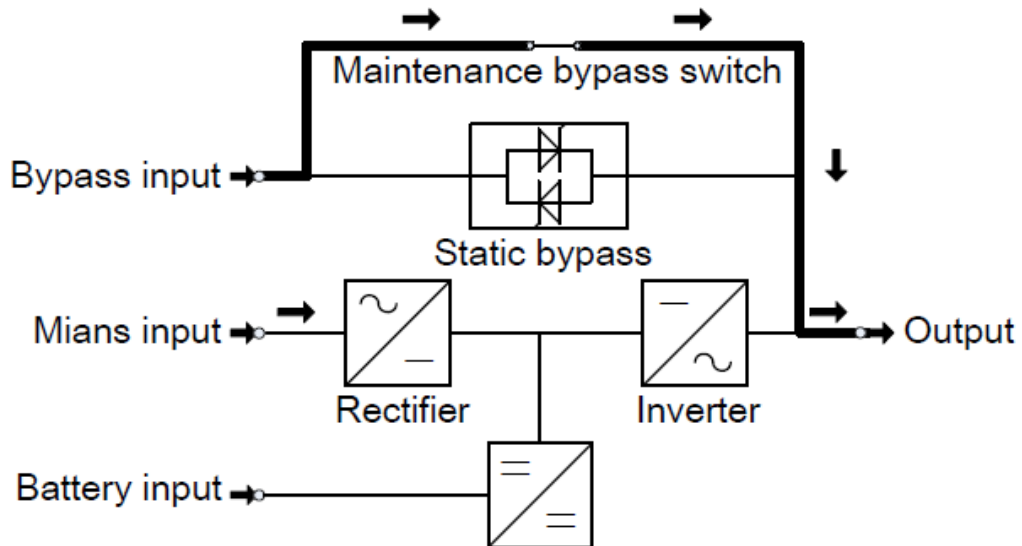

4.2 Turn on/off UPS

4.2.1 Restart procedure



CAUTION!

MAKE SURE GROUNDING IS PROPERLY DONE!

- ◆ Set the Battery Breaker to the “ON” position according to the user’s manual.



CAUTION!

Check to see if the load is safely connected with the output of the UPS. If the load is not ready to receive power from the UPS, make sure that it is safely isolated from the UPS output terminals

- ◆ Turn ON OUTPUT breaker.
- ◆ Turn ON BYPASS breaker and MAINS breaker.

If the Rectifier input is within voltage range, the rectifier will start up in 30 seconds then the inverter will start up after then.

If the rectifier fails at startup, the bypass LED will light up. When the inverter starts up, the UPS will transfer from bypass mode to inverter mode, then the bypass LED extinguishes and the inverter LED lights up.

No matter whether the UPS can work normally or not, all the status will be shown on the LCD display.

4.2.2 Test procedure



CAUTION!

The UPS is operating normally. It may take 60 seconds to boost up the system and perform self-test completely.

- ◆ Switch off the MAINS to simulate utility failure, the rectifier will turn off and the battery should feed the inverter without interruption. At this time, the LEDs of battery should be turned on.
- ◆ Switch on the MAINS to simulate utility recovery, the rectifier will restart automatically after 20 seconds and the inverter will supply to the load. It is suggested to use Dummy loads for testing. The UPS can be loaded up to its maximum capacity during load test °

4.2.3 MAINTENANCE BYPASS

To supply the load via Mains, you may simply active the internal mechanical bypass switch.



CAUTION!

The load is not protected by the UPS when the internal mechanical bypass system is active and the power is not conditioned.

Switch to mechanical bypass

CAUTION!



If the UPS is running normally and can be controlled through the display, carry out steps 1 to 6; otherwise, jump to Step 5.(if have)

- ◆ Open the cover of maintenance switch, the UPS turns to bypass mode automatically.
- ◆ Turn on MAINTENANCE breaker;
- ◆ Switch OFF BATTERY breaker;
- ◆ Switch OFF MAINS breaker;
- ◆ Switch OFF BYPASS breaker;
- ◆ Switch OFF OUTPUT breaker;

At this time the bypass source will supply to the load through the MAINTENANCE breaker.

Switch to normal operation(from mechanical bypass)

CAUTION!



Never attempt to switch the UPS back to normal operation until you have verified that there are no internal UPS faults.(if have)

- ◆ Turn ON OUTPUT breaker.
- ◆ Turn ON BYPASS breaker.
- ◆ Turn ON MAINS breaker.

The UPS powers from the static bypass instead of the maintenance bypass, then the bypass LED will light up.

- ◆ Switch OFF the maintenance bypass breaker, then the output is supplied by the static bypass of the UPS.
- ◆ Put on the maintenance switch cover.

The rectifier will operate normally after 30 seconds. If the inverter works normally,

the system will be transferred from bypass mode to normal mode.

4.2.4 Cold start procedure

CAUTION!



Follow these procedures when the input AC Utility Failure, but battery is normal (if have)

- ◆ Turn on the BATTERY breaker.

The battery will feed the Auxiliary power board.

- ◆ Turn on the OUTPUT breaker.

- ◆ Trigger the cold start(Cold start) buttons the position 11 of the below drawing.

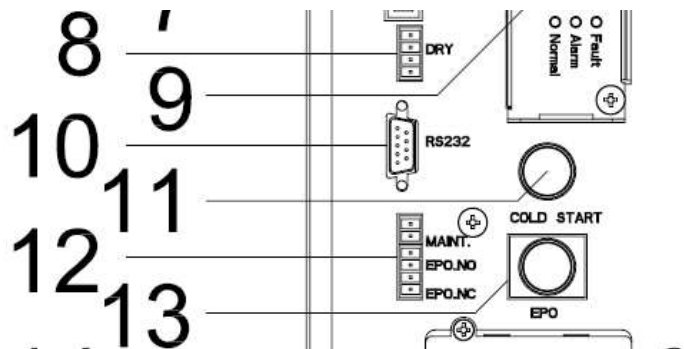

When battery normal, rectifier starts operation, 30s later, inverter starts and operates and battery LED on.

CAUTION!



Please press the close start button after 30 seconds until closing the battery switch.

4.2.5 Shut down procedure



CAUTION!

This procedure should be followed to completely shut down the UPS and the LOAD. After all power switches, isolators and circuit breakers are opened, there will be no output.

- ◆ Switch OFF the BATTERY breaker;
- ◆ Switch OFF the MAINS breaker.
- ◆ Switch OFF the BYPASS breaker.
- ◆ Open the OUTPUT breaker.The UPS shuts down;
- ◆ To completely isolate the UPS from AC Mains, all input switches of Utility shall be completely off, which includes the ones for rectifier and bypass.
- ◆ The primary input distribution panel, which is often located far away from the UPS area, so a label should be posted to advise service personnel that the UPS circuit is under maintenance.

WARNING!



Wait for about 5 minutes for the internal D.C. bus bar capacitors to

be completely discharged.

4.2.6 Parallel setting

- ◆ Find the SETTING button of LCD display, and click it.



- ◆ Input password, and go into the setting page.



- ◆ Select the "Working Mode" and click "Parallel", then check "OK" button to complete the setting.



4.3 The LCD Display



LCD panel

4.4 Options

SNMP card: internal SNMP / external SNMP optional

- ◆ Loosen the 2 torque screws (on each side of the card).
- ◆ Carefully pull out the card. Reverse the procedure for re-installation

The slot called SNMP supports the MEGAtec protocol. We advise that NetAgent II-3 port is also a tool to remotely monitor and manage any UPS system

NetAgent II-3Ports supports the Modem Dial-in (PPP) function to enable the remote control via the internet when the network is unavailable.

In addition to the features of a standard NetAgent Mini, NetAgent II has the option to add NetFeeler Lite to detect temperature, humidity, smoke and security sensors. Thus, making NetAgent II a versatile management tool. NetAgent II also supports multiple languages and is setup for web-based auto language detection.

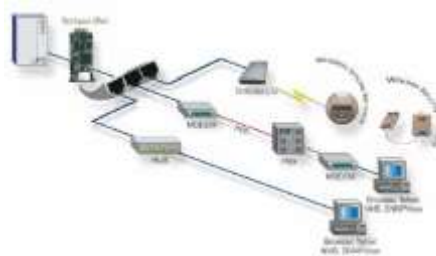

Typical topology of the UPS Network Management

Appendix 1 Specifications

Capacity (VA/W)	UPS		10KVA- 40KVA
Input	Phase		3Phase/4Wires + Ground
	Rated Voltage		380/400/415Vac
	Voltage Range		138~476Vac
	Frequency Range		40~70Hz
	Power Factor		≥0.99
	Bypass Voltage Range		Max.voltage: +15%(optional +5%、 +10%、 +25%) Min. voltage: -45% (optional -20%、 -30%) Frequency protection range: ±10%
	Current Harmonic		≤3(100% linear load)
Output	Phase		3Phase/4Wires + Ground
	Rated Voltage		380/400/415Vac
	Power Factor		0.9
	Voltage Precision		±1%
	Output Frequency	Utility Mode	±1%、 ±2%、 ±4%、 ±5%、 ±10% of the rated frequency(optional)
		Battery Mode	(50/60±0.2)Hz
	Crest Factor		3:1
	Transfer Time		Utility to Battery : 0ms Utility to bypass : 0ms (following)
	Overload Capacity		Load≤110%, 60min, ≤125%, last 10min, ≤150%last 1min, ≥150% shut down UPS immediately
	THD		≤2% with linear load ≤5% with non linear load
Efficiency			ECO mode ≥98%;Normal mode ≥95%
Communication Interface	UPS module		RS485、 SNMP card(optional)
Battery	Voltage		± 180V/± 192V/± 204V/± 216V/± 228V/± 240/± 252/ ± 264/± 276/± 288/± 300Vdc optional
	Charge Current(A)	UPS module	Maximum current 10A
	Backup time		Depends on the capacity of external batteries
Operating Environment	Temperature		0°C~40°C
	Humidity		0~95% non condensing
	Storage temperature		-25°C~55°C
	Altitude		< 1500m
Other	Unit Dimensions(W*H*D)	UPS module	485x130 x728mm
	Weight (Kg)	UPS module	23/25/25/26/28.5
Industry Standard			CE,EN/IEC 62040-2,EN/IEC 62040-1-1

Appendix 2 Problems and Solution

In case the UPS cannot work normally, it might be wrong in installation, wiring or operation. Please check these aspects first. If all these aspects are checked without any problem, please consult with local agent right away and provide below information.

(1) Product model name and serial number.

(2) Try to describe the fault with more details, such as LCD display info, LED lights status, etc.

Read the user manual carefully, it can help a lot for using this UPS in the right way. Some FAQ (frequently asked questions) may help you to troubleshoot your problem easily.

No.	Problem	Possible reason	Solution
1	Utility is connected but the UPS cannot be powered ON.	Input power supply is not connected; Input voltage low; The input switch of the UPS is not switched on.	Measure if the UPS input voltage/frequency is within the window. Check if UPS input is switched on
2	Utility normal but Utility LED does not light on, and the UPS operates at battery mode	The input breakers of the UPS are not switched on; input cable is not well connected	Switch on the input breaker; Make sure the input cable is well connected.
3	The UPS does not indicate any failure, but output do not have voltage	Output cable does not well connected; Output breaker do not switch on	Make sure the output cable is well connected; Switch on the output breaker.
4	Utility LED is flashing	Utility voltage exceeds UPS input range.	If the UPS operates at battery mode, please pay attention to the remaining backup time needed for your system.
5	Battery LED is flashing but no charge voltage and current	Battery breaker does not switch on, or batteries are damaged, or battery is reversely connected. Battery number and capacity are not set correctly.	Switch on the battery breaker. If batteries are damaged, need to replace whole group batteries, Connect the battery cables correctly; Go to LCD setting of the battery number and capacity, set the correct data.
6	Buzzer beeps every 0.5 seconds and LCD display "output overload"	Overload	Remove some load
7	The UPS only works on bypass mode	The UPS is set to ECO mode, or the transfer times to bypass mode are limited.	Set the UPS working mode to UPS type(non-parallel) or to reset the times of transferring to bypass or re-start the UPS
8	Cannot Black start	Battery switch is not properly closed: Battery fuse is not open: Or Battery low: Battery quantity set wrong; Power breaker in the rear panel not switch ON.	Close the battery switch: Change the fuse: Recharge the battery: Power ON the UPS with AC to set the battery quantity & quantity; Switch on the power breaker.

Appendix 3 USB communication port definition

Definition of port:

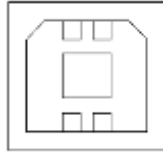

Connection between PC USB port and UPS USB port.

PC USB port	UPS USB port	Description
Pin 1	Pin 1	PC : +5V
Pin 2	Pin 2	PC : DPLUS signal
Pin 3	Pin 3	PC : DMINUS signal
Pin 4	Pin 4	Signal ground

Available function of USB

- ◆ Monitor UPS power status.
- ◆ Monitor UPS alarm info.
- ◆ Monitor UPS running parameters.
- ◆ Timing off/on setting.

Communication data format

Baud rate ----- 9600bps

Byte length ----- 8bit

End bit ----- 1bit

Parity check -----none



CAUTION!

USB and RS232 interface cannot be used at the same time, you can only use one of them at one time.

Appendix 4RS232 communication portdefinition

Definition of Male port:

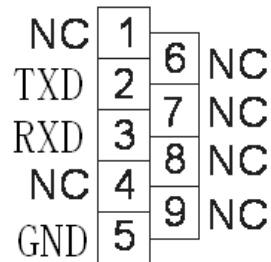

Connection between PC RS232 port and UPS RS232 port

PC RS232 port	UPS RS232 port	
Pin 2	Pin 2	UPS send,PC receive
Pin 3	Pin 3	PC send,UPS receive
Pin 5	Pin 5	ground

Available function of RS232

- ◆ Monitor UPS power status.
- ◆ Monitor UPS alarm info.
- ◆ Monitor UPS running parameters.
- ◆ Timing off/on setting.

RS-232 communication data format

Baud rate ----- 9600bps

Byte length ----- 8bit

End bit ----- 1bit

Parity check -----none



CAUTION!

USB and RS232interface cannot be used at the same time, you can only use one of them at one time.

Appendix 5 RS485 communication port definition

Definition of port:

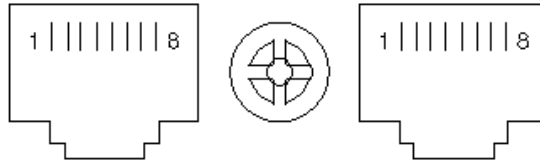

Connection between the Device's RS485 port and UPS RS485 port.

device(RJ45)	UPS(RJ45)	Description
Pin 1/5	Pin 1/5	485+“A”
Pin 2/4	Pin 2/4	485 - “B”
Pin7	Pin7	+12Vdc
Pin8	Pin8	GND

Available function of RS485

- ◆ Monitor UPS power status.
- ◆ Monitor UPS alarm info.
- ◆ Monitor UPS running parameters.
- ◆ Timing off/on setting.
- ◆ Battery environment temperature monitoring.
- ◆ Charging voltage modulation depending on batteries temperature

Communication data format

Baud rate ----- 9600bps

Byte length ----- 8bit

End bit ----- 1bit

Parity check -----none



CAUTION!

RS485 port pin7 is 12Vdc!

Appendix 6 Optional port definition

Definition of Male port:

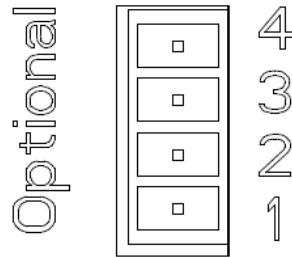

Instruction:

UPS	Instruction
Pin1	Normally NC
Pin2	Normally NO
Pin3	/
Pin4	Common

Function 1 description (Optional):

- ◆ Drive the bypass breaker when feedback alarm.

Function 2 description (Optional):

- ◆ Drive the battery breaker when battery voltage low.

Appendix 7 REPO instruction

Definition of port:

Connection diagram:

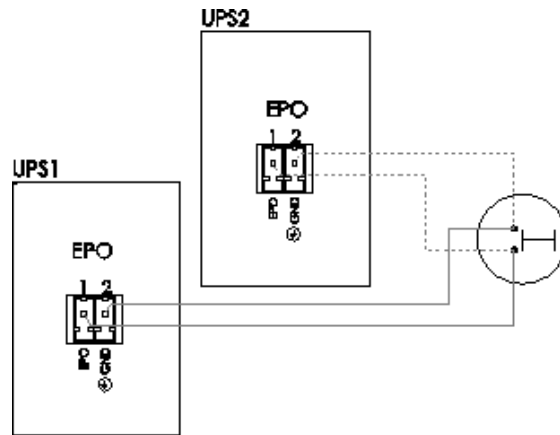

Connection between the button and UPS REPO port.

Button	UPS REPO	Description
Pin 1	Pin 1	EPO
Pin 2	Pin 2	GND

- ◆ A remote emergency stop switch (Photocoupler contact signal and “normally open” - not provided) can be installed in a remote location and connection through simple wires to the REPO connector.
- ◆ The remote switch can be connected to several UPS in a parallel architecture allowing the user to stop all units at once.